

General Arrangement / Dimensional Drawing - Face Mounted (B14) Brake Motor

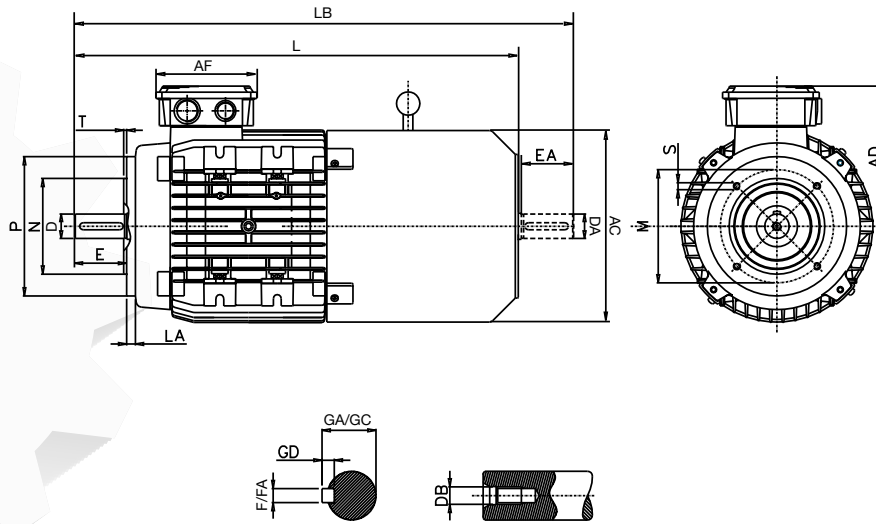

Frame	D/DA	E/EA	AD	AF	F/FA	L	LB	GA/GC	DB	AC	P	N	LA	M	T	S
63	11 j6	23	96.5	92	4	290	310	12.5	M4	123	90	60	8.5	75	2.5	M5
71	14 j6	30	111	92	5	331	358	16	M5	139	105	70	7.6	85	2.5	M6
80	19 j6	40	139	110	6	377	419	21.5	M6	155.6	120	80	9.5	100	3	M6
90S	24 j6	50	148	110	8	421	472	27	M8	176.6	140	95	9	115	3	M8
90L	24 j6	50	148	110	8	421	472	27	M8	176.6	140	95	9	115	3	M8
100L	28 j6	60	155	110	8	484	546	31	M10	192	160	110	10	130	3.5	M8
112M	28 j6	60	171	110	8	512	575	31	M10	221	160	110	10	130	3.5	M8
132S	38 k6	80	195	133	10	567	642	41	M12	248	200	130	23	165	3.5	M10
132M	38 k6	80	195	133	10	622	698	41	M12	248	200	130	23	165	3.5	M10
132M	38 k6	80	195	133	10	640	733	41	M12	248	200	130	23	165	3.5	M10
160M	42 k6	110	240.5	150	12	750	853	45	M16	317	250	180	20	215	4	M12
160L	42 k6	110	240.5	150	12	810	913	45	M16	317	250	180	20	215	4	M12

All Dimensions are in mm

Note- All the dimensions are indicative, may vary as actual.