

General Arrangement / Dimensional Drawing - Flange Mounted (B5) Brake Motor

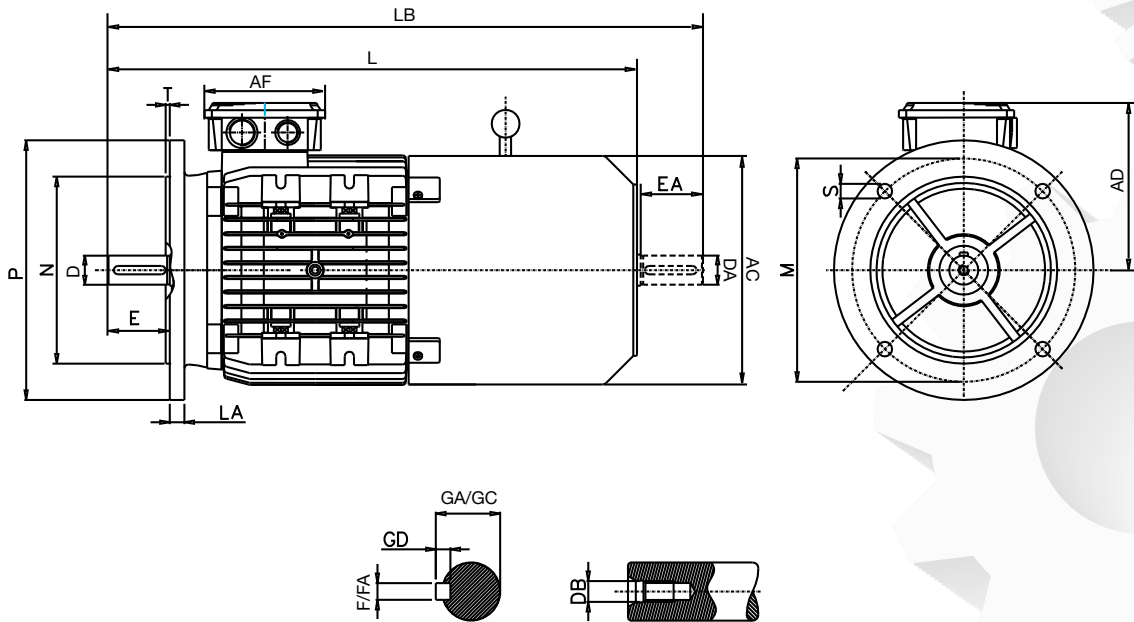

Frame	D/DA	E/EA	AD	AF	F/FA	GD	L	LB	GA/ GC	DB	AC	P	N	T	S	M	LA
63	11 j6	23	119	92	4	4	290	310	12.5	M4	123	140	95	3	9.5	115	8
71	14 j6	30	111	92	5	5	331	358	16	M5	139	160	110	3.5	9.5	130	10
80	19 j6	40	139	110	6	6	380	419	21.5	M6	156	200	130	3.5	11.5	165	10
90S	24 j6	50	150	110	8	7	421	472	27	M8	177	200	130	3.5	11.5	165	12
90L	24 j6	50	150	110	8	7	421	472	27	M8	177	200	130	3.5	11.5	165	12
100L	28 j6	60	155	110	8	7	484	546	31	M10	196	250	180	4	14	215	14
112M	28 j6	60	171	110	8	7	512	575	31	M10	221	250	180	4	14	215	14
132S	38 k6	80	224	180	10	8	595	642	41	M12	248	300	230	4	14	265	14
132M	38 k6	80	224	180	10	8	622	698	41	M12	248	300	230	4	14	265	14
160M	42 k6	110	250	150	12	8	810	853	45	M16	317	350	250	5	18	300	15
160L	42 k6	110	250	150	12	8	834	913	45	M16	317	350	250	5	18	300	15

All Dimensions are in mm

Note- All the dimensions are indicative, may vary as actual.