

### General Arrangement / Dimensional Drawing - Foot Mounted (B3) Brake Motor

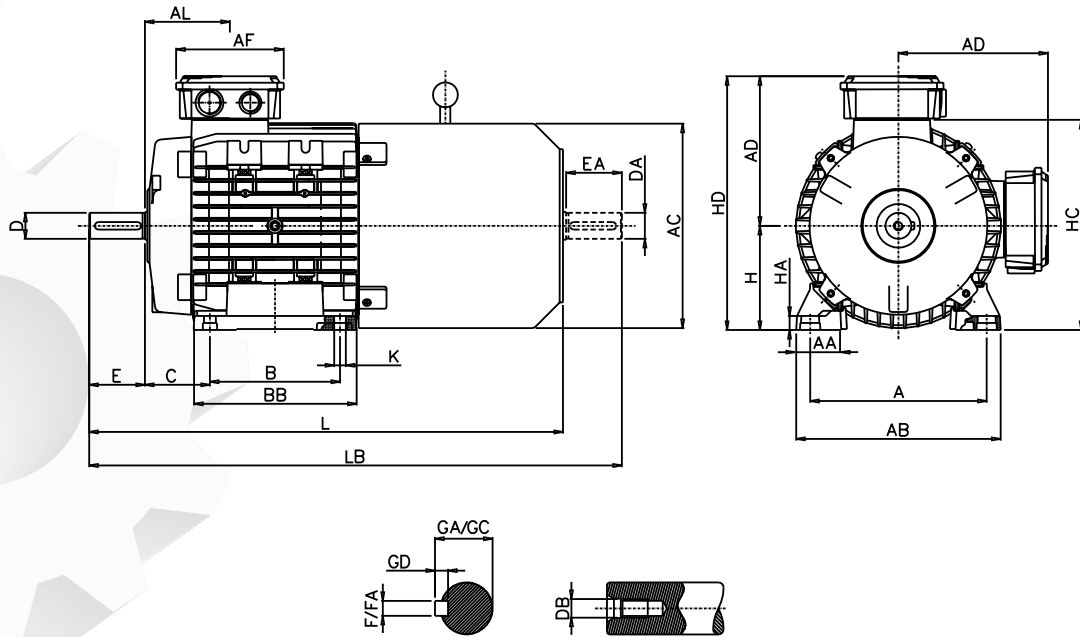

Frame	D/DA	E/EA	AD	AL	AF	F/FA	GD	L	LB	GA/GC	DB	AC	H	A	B	C	K	AB	BB	HD	HC	HA	AA
63	11 j6	23	96.5	66	92	4	4	290	310	12.5	M4	123	63	100	80	40	7	119	100	159.5	119.5	8	30
71	14 j6	30	131	69	110	5	5	331	358	16	M5	139	71	112	90	45	8	135	109	202	142	8	31
80	19 j6	40	139	79	110	6	6	377	419	21.5	M6	156	80	125	100	50	10	153	125	219	162	9.5	35
90S	24 j6	50	150	84.5	110	8	7	421	472	27	M8	176.6	90	140	100	56	10	170	150	240	181	11	37
90L	24 j6	50	150	84.5	110	8	7	421	472	27	M8	176.6	90	140	125	56	10	170	150	240	181	11	37
100L	28 j6	60	155	91	110	8	7	484	546	31	M10	196	100	160	140	63	11	192	166	255	198	12	44
112M	28 j6	60	171	91.5	110	8	7	512	575	31	M10	221	112	190	140	70	12	220	175	283	226	15	48.5
132S	38 k6	80	233	100	180	10	8	595	642	41	M12	248	132	216	140	89	12	256	218	365	261	15	59
132M	38 k6	80	233	120	180	10	8	622	698	41	M12	248	132	216	178	89	12	256	218	365	261	15	59
160M	42 k6	110	248	146	150	12	8	812	853	45	M16	317	160	254	210	108	15	308	270	408	317	23	76
160L	42 k6	110	248	168	150	12	8	840	913	45	M16	317	160	254	254	108	15	308	310	408	317	23	76

All Dimensions are in mm  
 Note- All the dimensions are indicative, may vary as actual.